

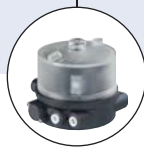

2/2-way Angle-Seat Valve with stainless steel design for medium up to +185°C, DN 13-50

- High flow rates
- High cycle life
- Flow optimised body in stainless steel
- Deliverable with flow direction below or above seat
- Clean design for optimal use in hygienic environment
- Suitable for steam up to 10 bar(g)

Type 2100 clamp can be combined with...



Type 8690

Pneum. control unit with feedback



Type 8691

Control head



Type 8695

Control head



Typ 8619

MultiCELL Transmitter/Controller



Typ 8222

Conductivity transmitter

In line with Bürkert's philosophy for modular valves and sensors the construction of the 2100 angle-seat valve fulfils tough criteria for process environments. Unrivalled cycle life and sealing integrity is guaranteed by the proven self adjusting spindle packing with V-seals.

The design enables the easy integration of automation modules whether they are electrical/optical position feedback, pneumatic control units, an integrated fieldbus interface or even an explosion proof feedback.

The fully integrated system has a compact and smooth design, integrated pneumatic lines, IP65/67 protection class and superior chemical resistance.

Technical data	
Orifice	DN 13 to 50
Port connections	ISO 2852, ASME BPE
Clamp acc. to	see separate datasheet
Weld and threaded	
Body material	Stainless steel 316L
Actuator material	
Actuator	PPS
Cover	Stainless steel 1.4561 (316Ti)
Sealing material	PTFE
Medium	Water, alcohol, oils, fuels, hydraulic fluids, salt solution, alkali solutions, organic solvents, steam
Viscosity	max. 600 mm ² /s
Spindle packing	PTFE V-rings with spring compensation
Medium temperature	-10 to +185 °C
Ambient temperature	0 bis +55 °C (integrated control head) 0 bis +60 °C (push-in air ports) 0 bis +100 °C (threaded air ports)
Control medium	Neutral gases, air
Max. pilot pressure	max. 10 bar; actuator size 130mm, 7 bar
Pilot air ports	Push-in connector for external ø 6 mm or 1/4" tube, thread G1/8 (on request)
Installation	As required, preferably with actuator in upright position
Surface Finish, standard	in internal connection area, Ra<=0.6 (mech. polished) on request Int. Ra ≤ 0.6 µm (external cast surface) electropolished

Content

Valve specifications		System spec. On/Off ELEMENT	Request for quotation
Type 2100		Type 8801-YE	Type 8801-YE
Technical data & ordering info.	p. 1-6	Ordering info. & technical data	p. 12

Technical data angle seat valve Type 2100 flow direction below the seat (for gases and liquids)

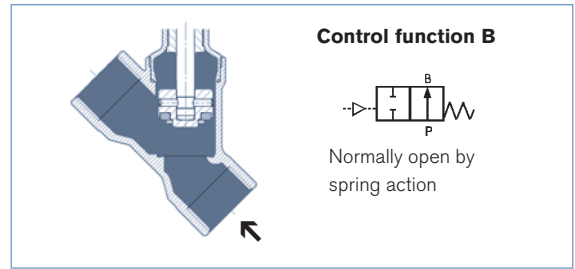
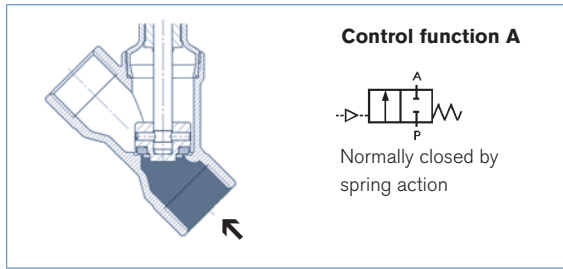

Orifice [mm]	Actuator size [mm]	Kv value water (m³/h)	Minimum pilot pressure SFA [bar]	Operating pressure up to +185°C	
				SFA [bar]	SFB [bar]
13	50	5	5.2	25	16
	70	5	5.0	25	16
20	50	10	5.2	16	16
	70	11	5.0	20	16
25	50	15	5.2	9	14.5
	70	18	5.0	16	16
32	70	27	5.0	8.5	16
	90	28	5.0	16	16
40	70	38	5.0	6	16
	90	40	5.0	16	16
50	70	52	-	-	16
	90	55	5.0	10	16
	130	62	5.0	16	16

Flow rate: Kv value water [m³/h]: Measured at +20 °C, 1 bar pressure at valve inlet and free outlet.

Pressure valves [bar]: Overpressure to the atmospheric pressure

Pressure charts with control function B and flow direction below the seat

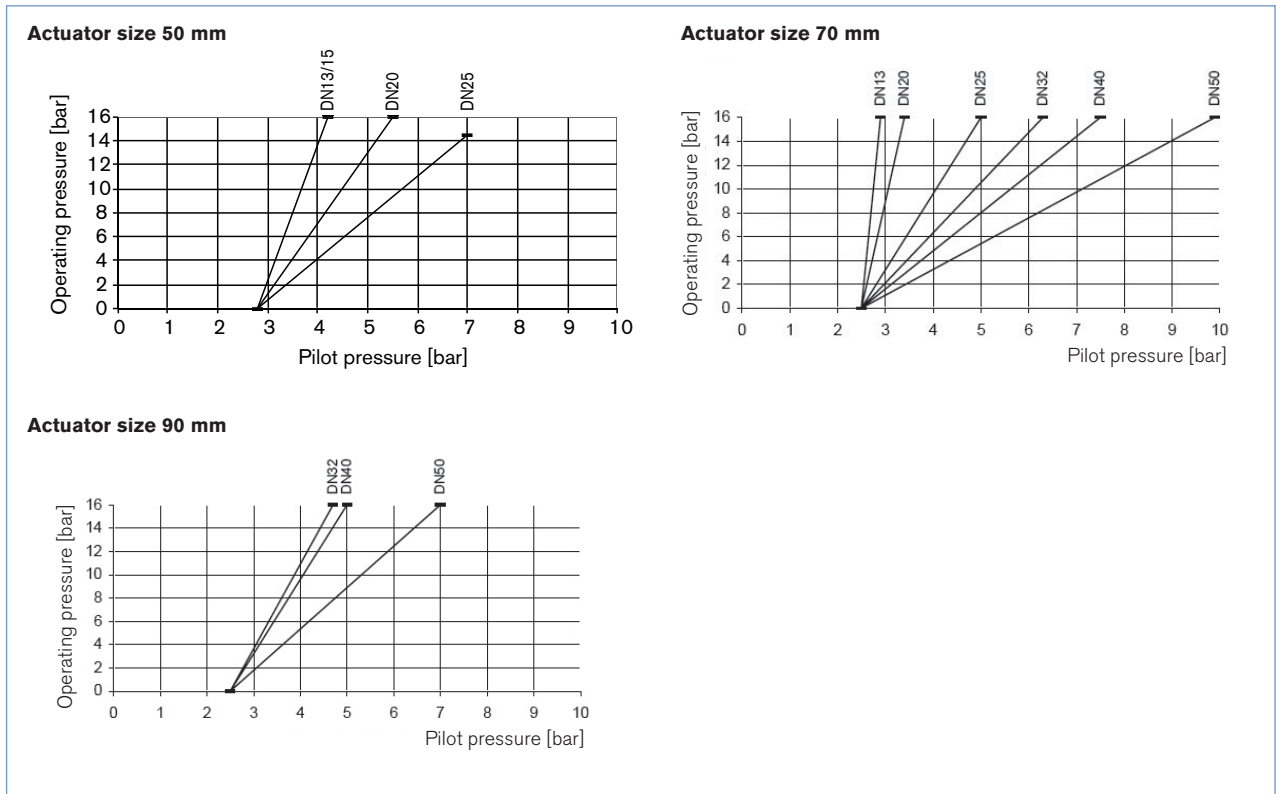

Ordering chart Type 2100, flow direction below the seat (for gases and liquids)

Clamp acc. to ISO 2852, flow direction below the seat

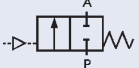
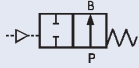
Control function	Orifice (mm)	Actuator size \varnothing [mm]	Port connection clamp external \varnothing (mm)	Minimum pilot pressure [bar]	Operating pressure up to +185 °C [bar]	Item no.
A 2/2-way valve, NC 	15	50	34.0	5.2	25	187 097
	15	70	34.0	5.0	25	188 783
	20	50	50.5	5.2	16	209 437
	20	70	50.5	5.0	20	188 784
	25	50	50.0	5.2	9	227 613
	25	70	50.5	5.0	16	188 785
	32	70	50.5	5.0	8.5	188 786
	32	90	50.5	5.0	16	188 787
	40	70	64.0	5.0	6	188 788
	40	90	64.0	5.0	16	188 789
	50	90	77.5	5.0	10	188 790
		130	77.5	5.0	16	188 791
B 2/2-way valve, NO 	15	50	34.0	see chart on p. 2	16	187 101
	15	70	34.0		16	188 800
	20	50	50.5		16	187 102
	20	70	50.5		16	188 801
	25	70	50.5		16	188 802
	32	70	50.5		16	188 803
	40	70	64.0		16	188 804
	50	70	77.5		16	188 805

Clamp acc. to ASME BPE, flow direction below the seat

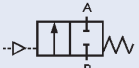
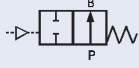
Control function	Orifice (mm)	Actuator size \varnothing [mm]	Port connection clamp external \varnothing (mm)	Minimum pilot pressure [bar]	Operating pressure up to +185 °C [bar]	Item no.
A 2/2-way valve, NC 	15	50	25.0	5.2	25	187 103
	15	70	25.0	5.0	25	188 806
	20	50	25.0	5.2	16	227 614
	20	70	25.0	5.0	20	188 807
	25	50	50.5	5.2	9	227 615
	25	70	50.5	5.0	16	188 808
	40	70	50.5	5.0	6	188 809
	40	90	50.5	5.0	16	188 810
	50	90	64.0	5.0	10	188 811
			130	64.0	5.0	16
B 2/2-way valve, NO 	15	50	25.0	see chart on p. 2	16	187 107
	15	70	25.0		16	188 820
	20	50	25.0		16	187 108
	20	70	50.5		16	188 821
	25	70	50.5		16	188 822
	40	70	50.5		16	188 823
	50	70	64.0		16	188 824

 Further versions on request

 Control function
I (double-acting)

Technical data angle seat valve Type 2100 flow direction above the seat (for gases and steam)

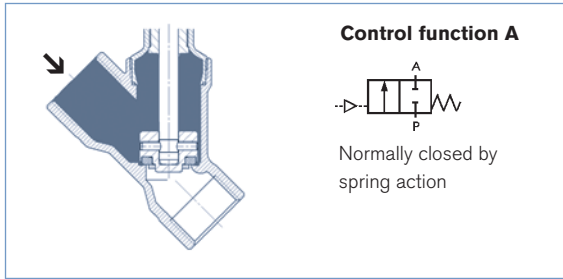

Attention!

Valves with flow above the seat are only conditionally usable for liquid medium. There is a danger of waterhammer!

Orifice [mm]	Actuator size [mm]	Kv value water (m ³ /h)	Operating pressure up to +185°C NC (A) [bar]
13	50	5	16
	70	5.1	16
20	50	10	16
	70	12	16
25	50	15	16
	70	19	16
32	70	28	16
40	70	38	16
	90	40	16
50	70	50	12
	90	55	16

Flow rate: Kv value water [m³/h]: Measured at +20 °C, 1 bar pressure at valve inlet and free outlet.

Pressure valves [bar]: Overpressure to the atmospheric pressure

Pressure charts with control function A and flow direction above the seat

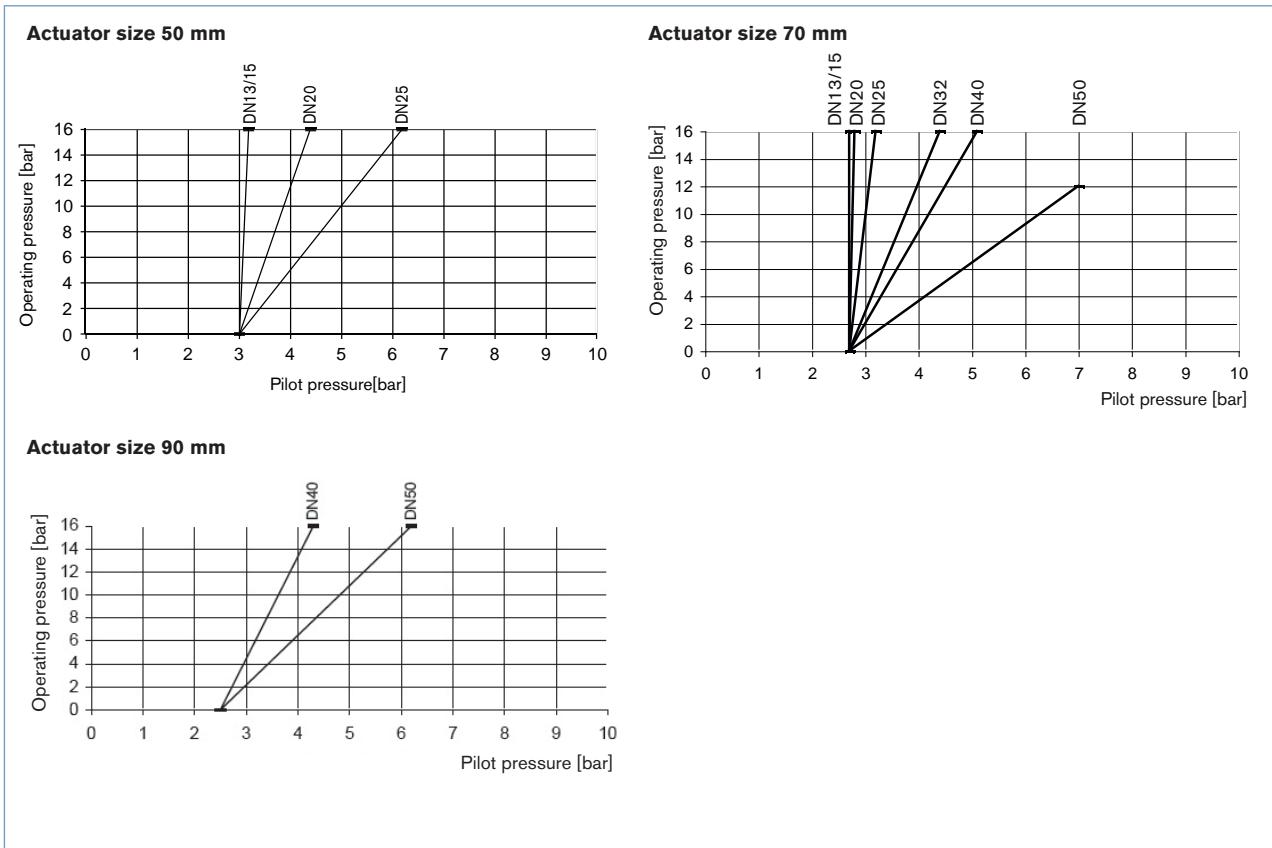

Ordering chart Type 2100 flow direction above the seat (for gases and steam)

Clamp acc. to ISO 2852, flow direction above the seat

Control function	Orifice (mm)	Actuator size \varnothing [mm]	Port connection clamp external \varnothing (mm)	Minimum pilot pressure [bar]	Operating pressure up to +185 °C [bar]	Item no.
A 2/2-way valve, NC 	15	50	34.0	see chart on p. 4	16	187 098
	20	50	50.5		16	187 099
	25	50	50.5		16	187 100
	32	70	50.5		16	188 795
	40	70	64.0		16	188 796
	50	70	77.5		12	188 798

Clamp acc. to ASME BPE, flow direction above the seat

Control function	Orifice (mm)	Actuator size \varnothing [mm]	Port connection clamp external \varnothing (mm)	Minimum pilot pressure [bar]	Operating pressure up to +185 °C [bar]	Item no.
A 2/2-way valve, NC 	15	50	25.0	see chart on p. 4	16	187 104
	20	50	25.0		16	187 105
	25	50	50.5		16	187 106
	40	70	50.5		16	188 816
	50	70	64.0		12	188 818

Materials angle seat valve Type 2100

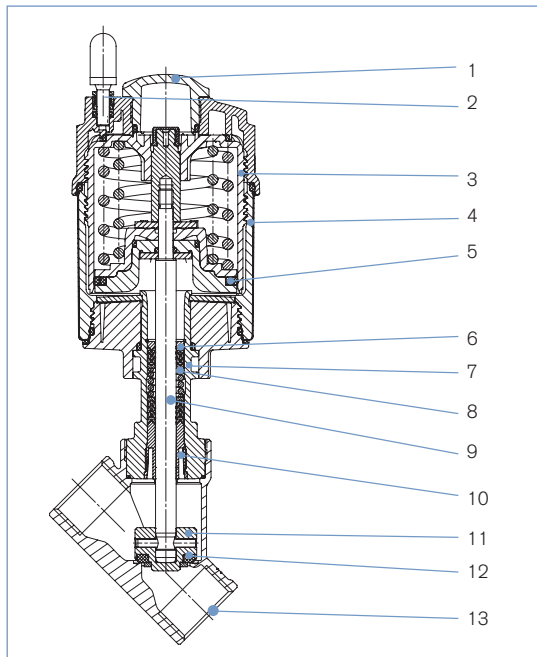

- | | | |
|-----------|-----------------------------------|--|
| 1 | Optical position indicator | Transparent cap polysulfone PSU |
| 2 | Pilot air ports | Push-in connector PP (standard)
<i>On request:</i>
Thread G1/8" stainless steel 1.4305 |
| 3 | Actuator | PPS |
| 4 | Cover | Stainless steel 1.4561 (316Ti) |
| 5 | Piston seal | FKM |
| 6 | Spring | Stainless steel 1.4310 |
| 7 | Pipe | Stainless steel 1.4401 (316)/1.4404 (316L) |
| 8 | Spindle packing | PTFE |
| 9 | Spindle | Stainless steel 1.4401 (316)/1.4404 (316L) |
| 10 | Wiper | PEEK |
| 11 | Swivel plate | Stainless steel 1.4401 (316)/(1.4404 (316L) |
| 12 | Seals | PTFE |
| 13 | Valve body | Stainless steel 316L |

Lubricants for spindle packing and actuator are classified according NSF H1

Dimensions angle seat valve Type 2100 [mm], *continued*

Clamp body

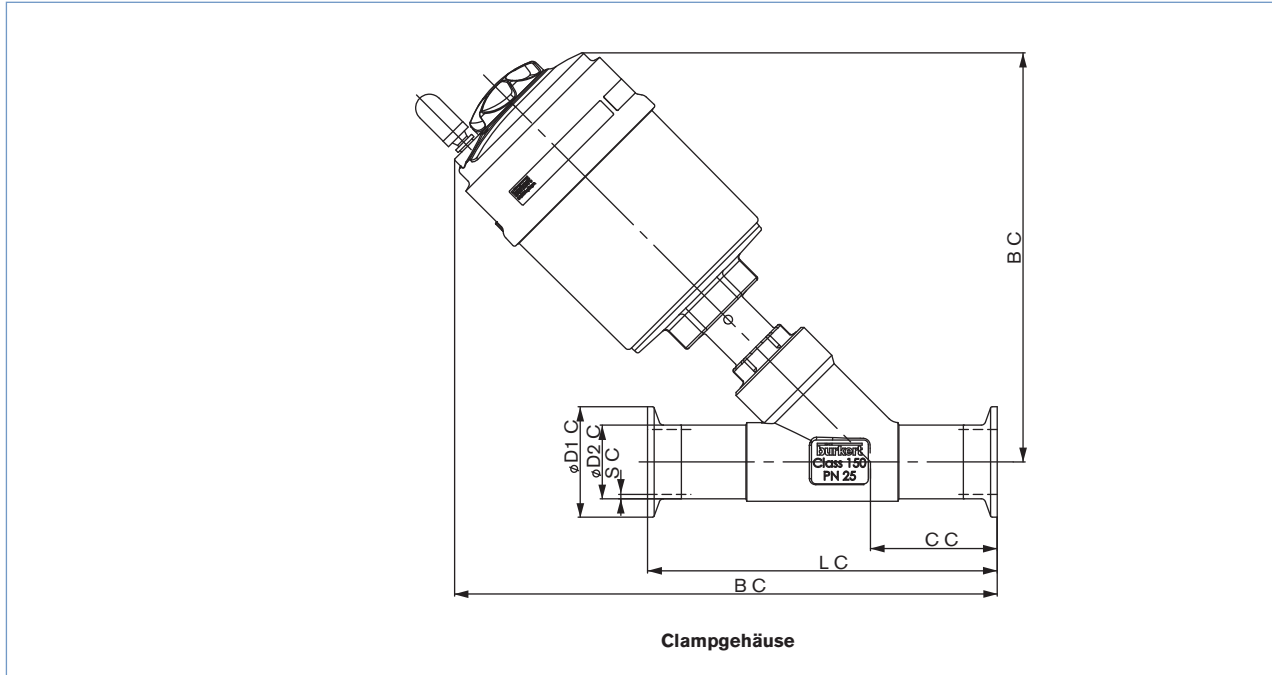

ISO 2852, DIN 32676

All bodies				Clamp body acc. to ISO 2852						DIN 32676					
Orifice [mm]	Actuator size [mm]	HC	BC	CC	LC	øD1C	øD2C	SC	LTA	CC	LC	øD1C	øD2C	SC	LTA
15	50	163	215	49	130	34	21.3	1.6	TC42	49.5	130	34	19	1.5	TD42
	70	178	231												
20	50	171	230	56.5	150	50.5	26.9	1.6	TC43	57	150	34	23	1.5	TD43
	70	186	246												
25	50	172	233	58	160	50.5	33.7	2	TC44	58.5	160	50.5	29	1.5	TD44
	70	188	249												
32	70	197	258	57.5	180	50.5	42.4	2	TC45	58	180	50.5	35	1.5	TD45
	90	242	300												
40	70	201	273	69	200	64	48.3	2	TC46	69.5	200	50.5	41	1.5	TD46
	90	245	31												
	130	296	365												
50	70	219	300	77.5	230	77.5	60.3	2.6	TC47	78	230	64	53	1.5	TD47
	90	261	340												
	130	312	389												

BS 4825, ASME BPE

All bodies				Clamp body acc. to BS 4825						ASME BPE					
Orifice [mm]	Actuator size [mm]	HC	BC	CC	LC	øD1C	øD2C	SC	LTA	CC	LC	øD1C	øD2C	SC	LTA
15	50	163	215	49	130	25.2	12.7	1.2	TH42	49	130	25	12.7	1.65	TG02
	70	178	231												
20	50	171	230	56.5	150	25.2	19.05	1.2	TH43	56.5	150	25	19.05	1.65	TG03
	70	186	246												
25	50	172	233	58	160	50.5	25.4	1.65	TH44	-	-	-	-	-	-
	70	188	249												
40	70	201	273	69	200	50.5	38.1	1.65	TH46	-	-	-	-	-	-
	90	245	31												
	130	296	365												
50	70	219	300	77.5	230	64	50.8	1.65	TH47	-	-	-	-	-	-
	90	261	340												
	130	312	389												

Ordering information for valve system On/Off ELEMENT Type 8801-YE

A valve system On/Off ELEMENT Type 8801-YE consists of an angle seat valve Type 2100 and a pneumatic control unit Type 8690, control head Type 8691 (for valve actuator sizes $\varnothing 70/\varnothing 90/\varnothing 130\text{mm}$) or control head Type 8695 (for valve actuator size $\varnothing 50\text{ mm}$) (see separate datasheets).

For the configuration of further valve systems please use the "Request for quotation" on p. 12 [go to page](#)

You order two components and receive a complete assembled and certified valve.

Ordering the valve system On/Off ELEMENT Type 8801-YE with valve actuator sizes $\varnothing 70/\varnothing 90/\varnothing 130\text{mm}$

Angle seat valve Type 2100 with actuator sizes $\varnothing 70/\varnothing 90/\varnothing 130\text{ mm}$

Control units



Pneum. control unit
Type 8690



Control head
Type 8691

Angle seat valve with desired control unit



**Valve system On/Off ELEMENT Type 8801-YE-K
2100 + 8690**



**Valve system On/Off ELEMENT Type 8801-YE-H
2100 + 8691**

Click on the orange box "More info." below... you will come to our website for the resp. product where you can download the datasheet.

Pneumatic control unit Type 8690



More info.

The new generation of integrated controllers for combination with actuators from the process valve series Type 21xx is specially designed for the requirements of hygienic process environments. The pneumatic control unit Type 8690 combines electrical position feedback and pneumatic control for single or double-acting actuators, and is also optionally available as an intrinsically safe model to ATEX.

Main customer benefits:

- Compact design of the valve system with integrated controller meets the demands for plant washdown environments through the selection of materials, external seals and integrated control air supply to the actuator.
- Integrated pilot valve with manual actuation
- Air intake filter enhances the process valve system availability
- Simple and reliable actuator adaptations allowing additional actuators of the process valve series, Type 20xx or actuators from other manufacturers to be used

Control head Type 8691



More info.

The new generation of integrated control heads for combination with actuators from the process valve series Type 21xx is specially designed for the requirements of hygienic process environments. The intelligent control head, Type 8691, detects the valve position by means of a contact-free analog position sensor circumventing excessive wear of mechanical parts. Single or double-acting actuators are controlled via the integral pilot valve. Communication interfaces AS-Interface and DeviceNet are available as options.

Main customer benefits:

- Compact, hygienic design of the valve system with integrated controller meets the demands of plant washdown environments through the selection of materials, external seals and integrated control air supply to the actuator.
- Automatic setting of the control head at the push of a button
- Even under dirty or dark environments, a clearly visible status display due to powerful LEDs
- Monitoring and diagnosis: Process valve systems with field bus interface used in modern plant processes
- Integrated pilot valve with manual actuation
- Air intake filter enhances the process valve system availability
- Simple and reliable actuator adaptations allowing additional actuators of the process valve series, Type 20xx or actuators from other manufacturers to be used

Ordering information for valve system On/Off ELEMENT Type 8801-YE, *continued*

A valve system On/Off ELEMENT Type 8801-YE consists of an angle seat valve Type 2100 and a pneumatic control unit Type 8690, control head Type 8691 (for valve actuator sizes $\varnothing 70/\varnothing 90/\varnothing 130\text{mm}$) or control head Type 8695 (for valve actuator size $\varnothing 50\text{mm}$) (see separate datasheets).

For the configuration of further valve systems please use the "Request for quotation" on p. 12 [go to page](#)

You order two components and receive a complete assembled and certified valve.

Ordering the valve system On/Off ELEMENT Type 8801-YE with valve actuator size $\varnothing 50\text{mm}$

Angle seat valve Type 2100 with actuator size $\varnothing 50\text{mm}$



Control unit



Angle seat valve with desired control unit



Click on the orange box "More info." below... you will come to our website for the resp. product where you can download the datasheet.

Control head Type 8695



More info.

The new generation of integrated control heads for combination with small actuators from the process valve series Type 21xx is specially designed for the requirements of hygienic process environments. The intelligent control head, Type 8695, detects the valve position by means of a contact-free analog position sensor circumventing excessive wear of mechanical parts. Single and double-acting actuators are controlled via the integral pilot valve. An AS-Interface communication interface is available as an option.

Main customer benefits:

- Compact, hygienic design of the valve system with integrated controller meets the demands of plant washdown environments through the selection of materials, external seals and integrated control air supply to the actuator
- Automatic setting of the control head at the push of a button
- Visual status display on the control head
- Monitoring and diagnosis: Process valve systems with fieldbus interface used in modern plant processes
- Integrated pilot valve
- Simple and reliable actuator adaption

Dimensions for valve system On/Off ELEMENT Type 8801-YE [mm]

Dimensions valve system On/Off ELEMENT Type 8801-YE with pneumatic control unit Type 8690 [mm]

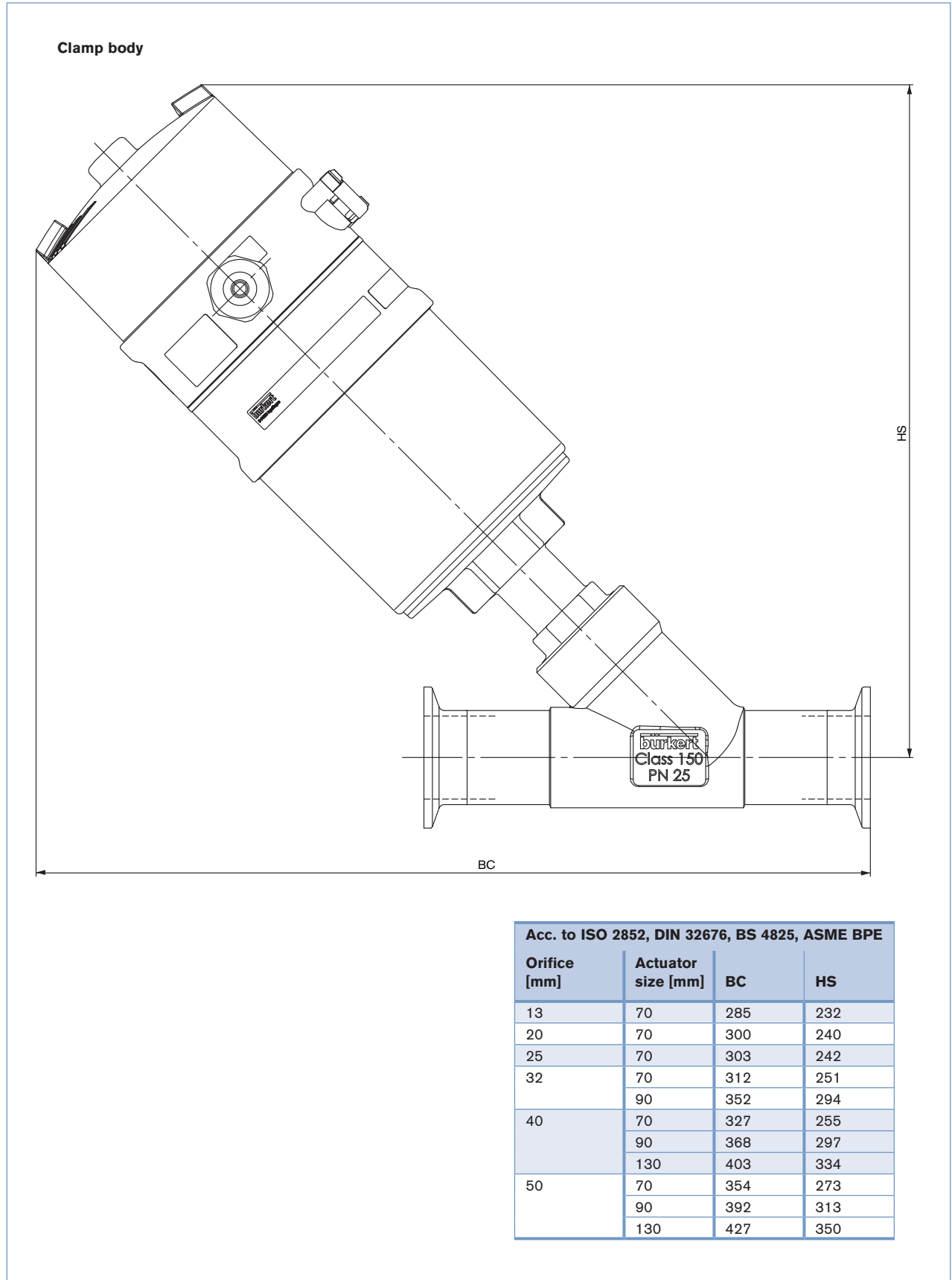

Dimensions for valve system On/Off ELEMENT Type 8801-YE [mm], *continued*

Dimensions valve system On/Off ELEMENT Type 8801-YE with control head Type 8691 [mm]

Clamp body

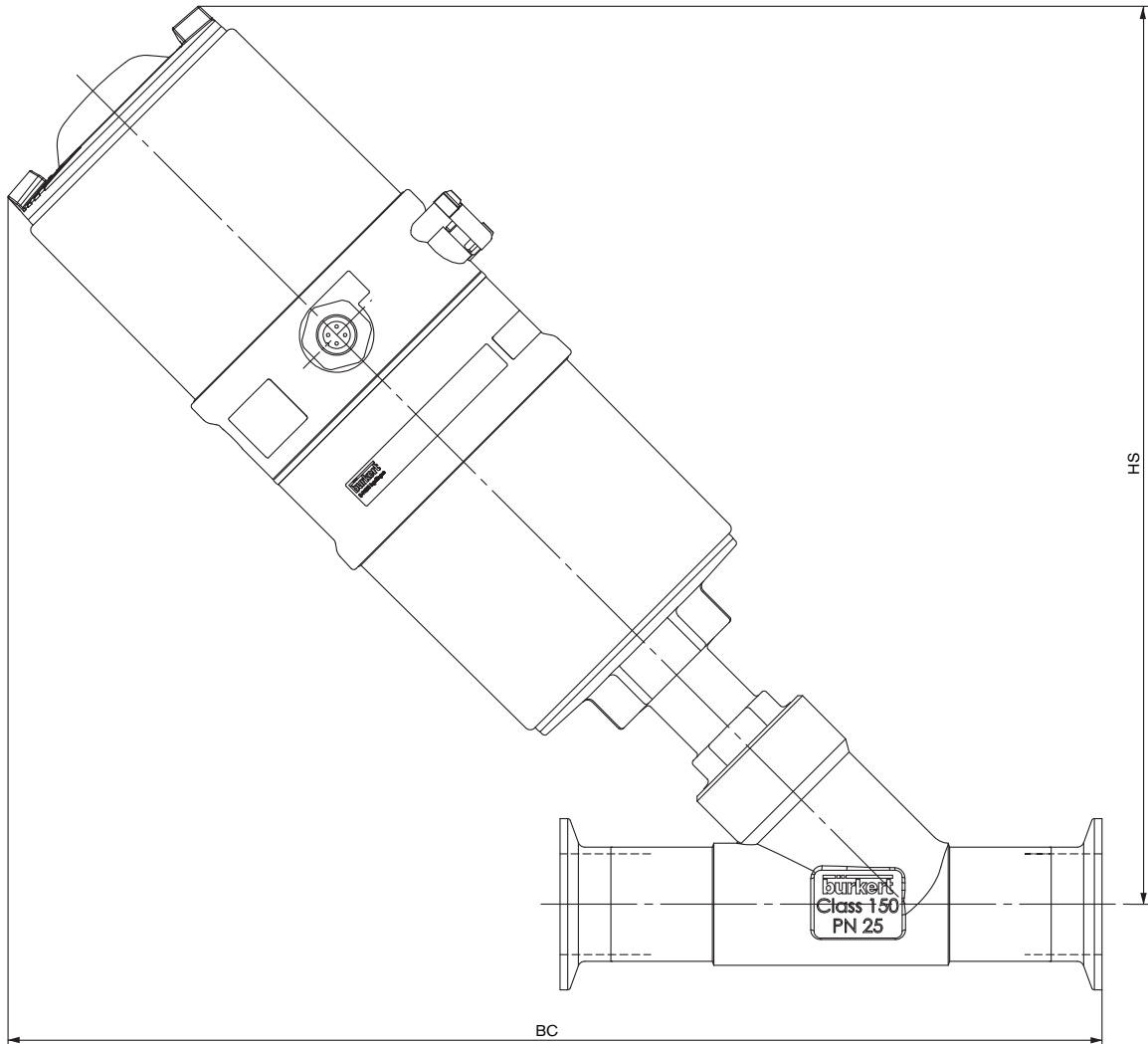

Acc. to ISO 2852, DIN 32676, BS 4825, ASME BPE			
Orifice [mm]	Actuator size [mm]	BC	HS
13	70	309	256
20	70	324	264
25	70	327	266
32	70	336	275
	90	376	318
40	70	351	279
	90	392	321
	130	427	358
50	70	378	297
	90	416	337
	130	451	374

Dimensions for valve system On/Off ELEMENT Type 8801-YE [mm], *continued*

Dimensions valve system On/Off ELEMENT Type 8801-YE with control head Type 8695 [mm]

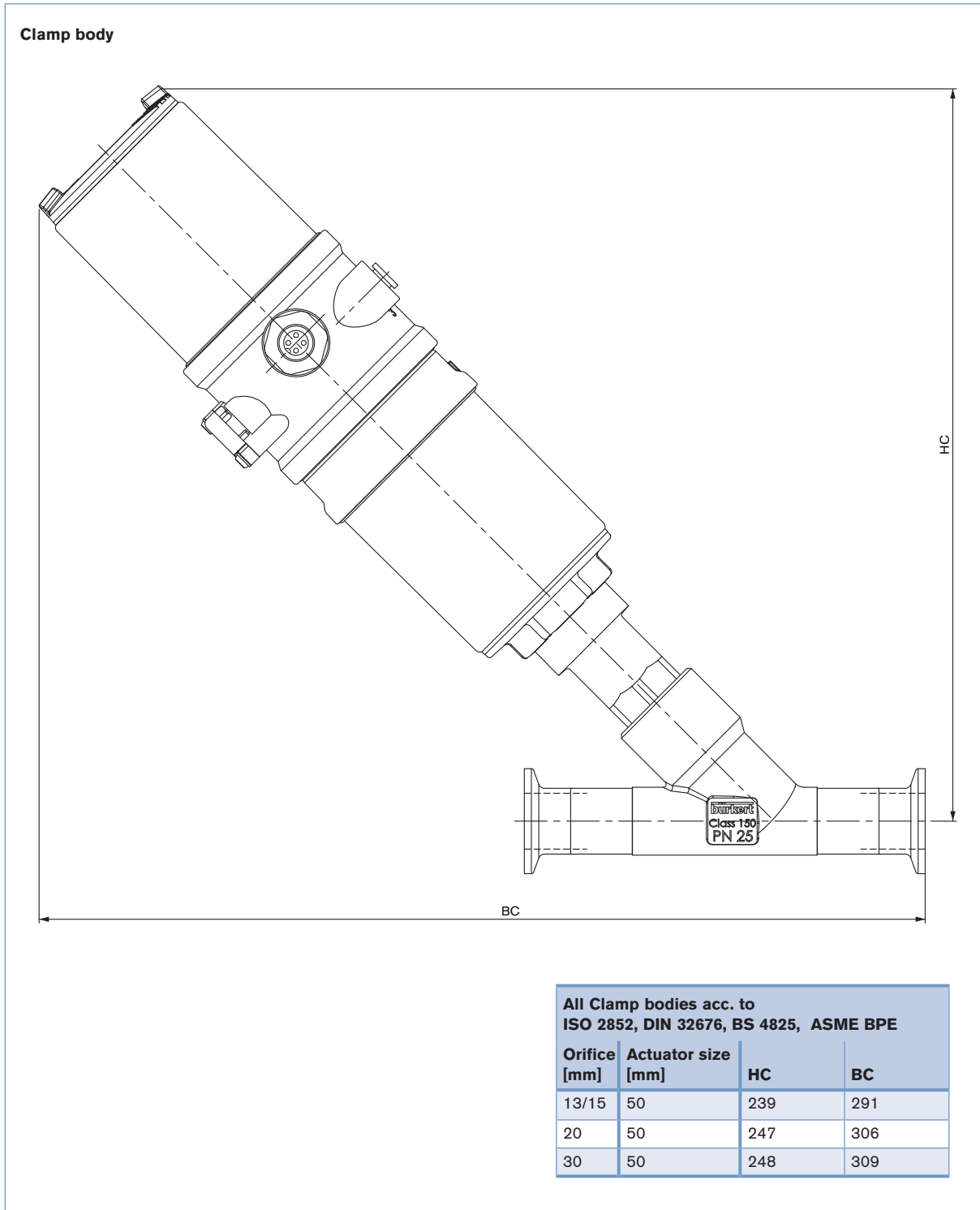

Valve system On/Off ELEMENT Type 8801-YE - Request for quotation

Note

You can fill out the fields directly in the PDF file before printing out the form.

Please fill out and send to your nearest Bürkert facility* with your inquiry or order

Company	Contact person
Customer no.	Department
Address	Tel./Fax
Postcode/town	E-mail

= mandatory fields to fill out Quantity Required delivery date

Operating data

Pipe line DN PN

Pipe material

Process medium

Type of medium Liquid Steam Gas

Valve features

Seal material PTFE NBR Other

Nominal pressure PN

Orifice DN

Type of connection Threaded Welded Clamp

Standard connection ISO DIN Other

Body material selection with welded connection, acc. to EN ISO 1127/ISO 4200 and DIN 11850 St. st. 1.4581 St. st. 316 L

Control function NC¹⁾ NO¹⁾ Double-acting

Pilot pressure min. max.

Please specify item no. if known:

¹⁾ NC: normally closed by spring action; NO: normally open by spring action

Control unit features

For actuator sizes ø70/ø90/ø130 mm		For actuator size ø50 mm
<input type="checkbox"/> Pneumatic Control Unit Type 8690 More info.	<input type="checkbox"/> Control Head Type 8691 More info.	<input type="checkbox"/> Control Head Type 8695 More info.
<p>Pneumatic function</p> <p><input type="checkbox"/> Single-acting <input type="checkbox"/> Double-acting</p> <p><input type="checkbox"/> Without pilot valve</p> <p>Position feedback</p> <p><input type="checkbox"/> 1x inductive <input type="checkbox"/> 2x inductive</p> <p><input type="checkbox"/> 1x inductive (NAMUR) <input type="checkbox"/> 2x inductive (NAMUR)</p> <p><input type="checkbox"/> 1x mechanical <input type="checkbox"/> 2x mechanical</p> <p>Supply voltage</p> <p><input type="checkbox"/> 24 V / DC (ATEX Zone 2/22)</p> <p><input type="checkbox"/> Ex ia IIC T6 (ATEX Zone 1)</p> <p>Pilot air ports</p> <p><input type="checkbox"/> Push-in connector <input type="checkbox"/> Thread G 1/8" external ø 6mm or 1/4"</p> <p>Please specify item no. if known: <input type="text"/></p>	<p>Pneumatic function</p> <p><input type="checkbox"/> Single-acting <input type="checkbox"/> Double-acting</p> <p>Pilot air ports</p> <p><input type="checkbox"/> Push-in connector external ø 6mm or 1/4"</p> <p><input type="checkbox"/> Thread G 1/8"</p> <p>Communication</p> <p><input type="checkbox"/> ASI</p> <p><input type="checkbox"/> Multipol M12</p> <p><input type="checkbox"/> Flat cable clip, 1 m cable</p> <p><input type="checkbox"/> DeviceNet</p> <p>Please specify item no. if known: <input type="text"/></p>	<p>Pneumatic function</p> <p><input type="checkbox"/> Single-acting <input type="checkbox"/> Double-acting</p> <p><input type="checkbox"/> Push-in connector external ø 6mm or 1/4"</p> <p><input type="checkbox"/> Thread G 1/8"</p> <p>Communication</p> <p><input type="checkbox"/> ASI</p> <p>Please specify item no. if known: <input type="text"/></p>

Comments

* To find your nearest Bürkert facility, click on the orange box → www.burkert.com

In case of special application conditions, please consult for advice.

Subject to alteration.
© Christian Bürkert GmbH & Co. KG

1208/4_EU-en_00895155